



TECHNICAL DRAWINGS

INFOS

PRODUCT PHOTOS

DETAILS

APPLICATION
RECOMMENDATIONS

NEXT LEVEL SUPPORT.

EFFICIENCY ■ SALES ■ CUSTOMER LOYALTY



FOREWORD

Digitalisation has changed the way we see the world. In business, this has led to a fundamental change in the relationship between customers, dealers and manufacturers.

As competition becomes ever more intense, those who learn to adapt to market developments and benefit from them will be successful. For us in the B2B sector, the main question is how to offer customers added value and benefit.

LUKAS can help you find the right answers! Ever since we first started business, we have constantly been looking for solutions that go beyond the product and that help make both dealers and end users more successful. We call these NEXT LEVEL SOLUTIONS.

This brochure contains information on the following:

- LUKAS Standard 360° data package for greater efficiency, sales and customer loyalty
- How to create value by focusing on the transfer of knowledge, with practical training for dealers and customers
- How specialist retail ranges can deliver better product variety and availability

We look forward to creating a successful future with you!

Olaf Heimann
(Managing Director)



“LUKAS UNDERSTANDS WHAT DEALERS NEED TO PRESENT PRODUCTS IN A WAY THAT APPEALS TO CUSTOMERS.”

(D. Marold, REIDL GMBH & CO. KG)



TAKE THE FUTURE INTO YOUR HANDS TODAY

LUKAS at the cutting edge of a global industry

As one of the technological leaders in the market for grinding, milling, cutting and polishing systems, LUKAS specialises in the production and sale of tools, machinery and accessories, as well as expert consulting.

All of the products that we make and sell offer outstanding quality. Powerful, durable and extremely ergonomic, they help deliver excellent results in a variety of high-precision processes.

We aim to combine quality and reliability with the answers to the questions of the future. That is why we always look out for the latest technologies and developments from a range of industries. This focus gave us the lead early on in the market and still does to this day.

We are internationally active, with branches and representatives in Europe, America, Asia, Africa and Oceania. With over 80 years of experience, we produce system solutions for industries ranging from automotive, aerospace and energy to construction and tradespeople.



CONTENT

▪ LUKAS Standard 360° data package	4
▪ Knowledge Transfer	11
▪ Lukas-Online	14
▪ Retail Trade Selection	15

THE LUKAS STANDARD 360° DATA PACKAGE

BOOST EFFICIENCY, SALES AND CUSTOMER LOYALTY WITH
COMPREHENSIVE TOOL AND PRODUCT DATA

UNLOCK YOUR FULL POTENTIAL

Sales through online platforms and shop systems have been rising for years in virtually all industries. It is therefore no surprise that these channels are increasingly being used to sell professional tools as well. Industrial customers in particular like to purchase products online, and this trend looks set to continue. Thus, it is not surprising that specialist retailers are increasingly focusing on selling through their own online shop or marketplaces.

Serving customers well and offering them a superior customer experience is all about providing the right data about products, services and potential applications. But this is often a painstaking process that requires expert and customer knowledge.

UPGRADE YOUR WEB SHOP WITH THE LUKAS STANDARD 360° DATA PACKAGE

As a partner to retail, LUKAS always aims to make it easy for you to present our products in a modern way with the perfect amount of information. The free LUKAS Standard 360° data package gives you the latest information about all the items in the LUKAS catalogue ready for your online shop or product database, and with a level of information that only LUKAS can offer.

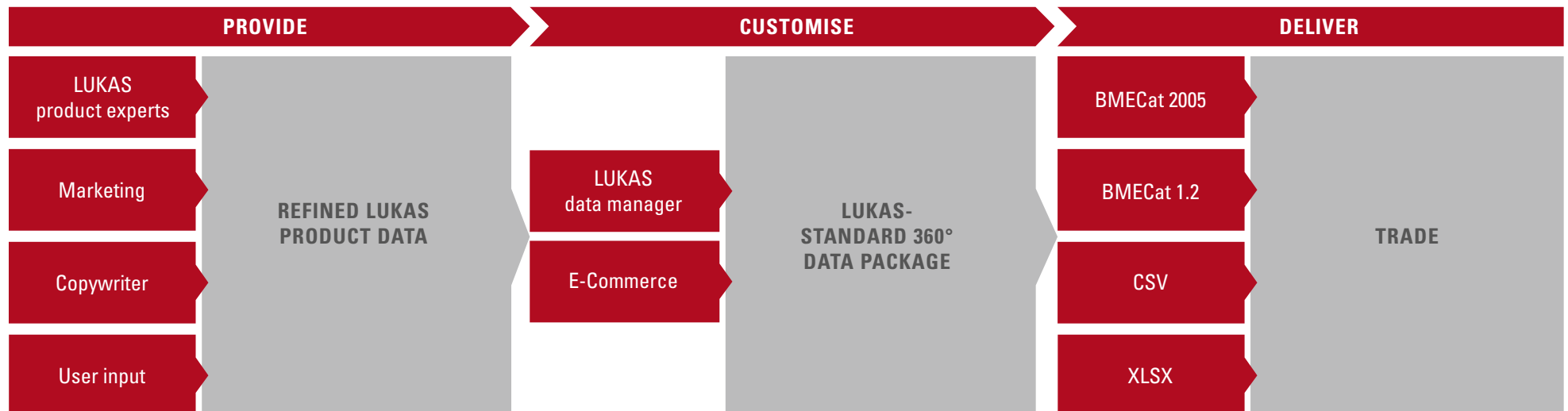



Conditions

CONDITIONS FOR RECEIVING DATA

- 1. Business relationship (offer from LUKAS)
- 2. Signed agreement on the use of LUKAS advertising material (provided by LUKAS)

Contact

REQUEST THE LUKAS STANDARD 360° DATA PACKAGE NOW

Would you like to find out how LUKAS' comprehensive product data can help you make your online platforms even better? Then get in touch with our data managers.

Contact:
Phone +49 (0) 2263 84-451
OnlineService@lukas-erzett.de

Example download

Use the QR code below to download a sample of our LUKAS data. The data is available in the standard formats such as BMECat 2005, BMECat 1.2, CSV and XLSX so that you can integrate it easily into your ERP, PIM or shop system.



CUSTOMER TESTIMONIAL



"LUKAS understands what we as dealers need to present products online in a way that appeals to customers. Best of all, they do almost all the work for us. This makes it easier for us to generate more sales. In terms of data quality and scope, LUKAS is one of the best in the business."

Dominik Marold,
strategic purchaser for REIDL GMBH & CO.
and for construction machinery of the Beutlhauser Group, specialising in digitalisation and data management



STRONG PRODUCT NAME

MAIN IMAGE

MARKETING CLAIM

FURTHER PRODUCT IMAGES

TOP FEATURES

MACHINE ICON

BENEFITS TEXT

TECHNICAL DRAWING

APPLICATION IMAGE

PERFORMANCE CLASSIFICATION AT A GLANCE

COMPREHENSIVE TOOL DETAILS

APPLICATION RECOMMENDATIONS

MATERIAL SUITABILITY

ADDITIONAL DATA SHEETS



- Dank eines hochfesten Harzsystems ist dieses Werkzeug auch bei hohen Arbeitstemperaturen nicht. Zusätzlich sind bei der Herstellung auf Umwelt- und moderne Technologien mit kurzen Auslaufzeiten genutzt.
- Die Stahlgehäuse des Werkzeugs ist exklusiv bei LUKAS erhältlich. Die in Träger basierte höchste Sicherheit (kein Bruch) und kann so gut auch im Roboter- einsetzbar. Die gute Wärmeabfuhr sorgt zudem für einen kühlen Schliff und ein Nacharbeiten.

LUKAS Schligffamenteller SLTT HybridPerfection Ø 125 mm Ceramicx Korn 40 | Flach

LUKAS-patentiertes Lamellenform mit innovatives Schleifritze für höchste Ergonomieerträge in härtesten Einsatz.

Artikelnummer: A27201230400044

Im Mehrwert

- Höher und schneller Abtrag besonders auf gehärteten Oberflächen, Zunder, Hart-Beschichtungen und Panzerschweißnähten
- Kein Bruch des Werkzeuges dank robuster Stahlgehäuse
- Hohe Lebensdauer durch mehrlagigen Schleifbelag
- Kosteneffizienz durch optimale Ausnutzung des kompletten Schleifbelags dank speziell geformter Lamellen
- Zersetzt auch härteste Werkstoffe effizient
- Keine Einblendung dank optimierter Wärmeabfuhr. Weniger Nacharbeit nötig
- Innerer frischer Schleifbelag im Einsatz. Verschleiß legt darauffolgende Lamellen frei
- Mehr Schleifen im Außenbereich für ein hohe Schlaggeschwindigkeit
- Sicheres Arbeiten auch bei hohen Drehgeschwindigkeiten und Temperaturen dank spezieller Hartverlebung
- Hohe Härte und Schärfe für eine beeindruckende Lebensdauer
- Auch für den Roboterersatz bestens geeignet
- Mehr Leistung, höhere Abtragsgeschwindigkeit und bessere Oberflächengüte mit einer Schüsselschabe
- Umweltschonend hergestellt mit moderner Harz-Auslauftechnologie
- Hohe Lebensdauer

Vorteile

- Gehärtete Oberflächen, verschleißfeste Stahl-, Zunder- und Hartschichten, Trennlegierungen sowie Panzerschweißnähte stellen kein Problem dar und lassen sich in kurzer Zeit bearbeiten
- Die Stahlgehäuse des Werkzeugs ist exklusiv bei LUKAS erhältlich. Die stabile und robuste Träger bietet höchste Sicherheit (kein Bruch) und kann so gut auch im Roboterersatz genutzt werden. Die gute Wärmeabfuhr sorgt zudem für einen kühlen Schliff und macht wenig Nacharbeit nötig
- Dank mehrlagigen Schleifbelag ist dieses Werkzeug immer so scharf, wie beim ersten Einsatz. Wenn die äußeren Lamellen verschleifen, wird frischer Schleifbelag der darauffolgenden Lamellen freigelegt. So erreicht das Werkzeug eine hohe Lebensdauer und eine gleichbleibende Abtragsleistung
- Die Flach-Lage der optimal verbleibenden Schleiflamellen ermöglicht nicht nur eine erhöhte Arbeitssicherheit, sie schneidet auch den Verschleiß des Werkzeugs ein. Das Schleifen hat sich besonders fest in seiner Unterlage und wird optimal genutzt. Im Außenbereich des Werkzeugs befindet sich besonders viele Schleifritze, was zu einem besonders hohen Abtrag pro Minute führt. Ein hervorragender Abtrag ist garantiert
- Dank eines hochfesten Harzsystems ist dieses Werkzeug auch bei hohen Drehzahlen oder Arbeitstemperaturen nicht. Zusätzlich wird bei der Herstellung auf Umweltschutz geachtet und moderne Technologien mit kurzen Auslaufzeiten genutzt
- Die Stahlgehäuse des Werkzeugs ist exklusiv bei LUKAS erhältlich. Die stabile und robuste Träger bietet höchste Sicherheit (kein Bruch) und kann so gut auch im Roboterersatz genutzt werden. Die gute Wärmeabfuhr sorgt zudem für einen kühlen Schliff und macht wenig Nacharbeit nötig

Technische Details	
Werkzeugform	Flach
Anzahl Lamellen	25 Stück
Korngröße	40
Lamellenbreite	62,5 mm
Lamellenlänge	30 mm
n max.	12200 (1min)
Produktverpackung	Karton
Schleiflamellenherkunft	SLTT - iQ-Serie
Schleifritze	CER (Ceramic Korn)
Sicherheitsnorm	EN 13743
V max.	80 m/s
Verpackungsbeschriftung	LUKAS-ERZETT
Werkzeugaufnahme	Bohrung
Werkzeugaufnahmeabmessung	22,23 mm
Werkzeughdurchmesser	125 mm

Material	
Stahl und Stahlguss	gut geeignet
Legierte/Vergütete Stähle	gut geeignet
Werkzeugstähle	gut geeignet
Rost-/saure-/hitzebeständiger Stahl und Stahlguss	gut geeignet
Gussisen	gut geeignet
Aluminium-, Magnesium- und Kupfer-Legierungen	gut geeignet
Titan- und Nickel-Legierungen	gut geeignet
Kunststoff/Holz/Gummi	gut geeignet

Anwendung	
Anfasen	gut geeignet
Böhren	gut geeignet
Bürsten	gut geeignet
Entgraten	gut geeignet
Fenschleifen	gut geeignet
Fäsen	gut geeignet
Gravieren	gut geeignet
Gussputzen	gut geeignet
Kohlstauffeststellen	gut geeignet
Lack entfernen	gut geeignet
Polieren	gut geeignet
Präzisionsbearbeitung	gut geeignet
Reinigen	gut geeignet
Säubern	gut geeignet
Schlagschleifen	gut geeignet
Schweißnahtbearbeitung	gut geeignet
Stichmattieren	gut geeignet
Trennen	gut geeignet
Aufbauen	gut geeignet

Datenblätter	
Sicherheitsmerkmale	

THE LUKAS STANDARD 360° DATA PACKAGE AT A GLANCE

The LUKAS Standard 360° data package also gives you the following information for every product:

- Price (RRP)
- Reference items
- GTIN/EAN code
- LUKAS group/category
- Keywords (min. 10)
- eBay category
- Amazon category
- Packaging unit

PRODUCT DATA FROM LUKAS – AN UNBEATABLE BASIS FOR GREATER EFFICIENCY, SALES AND CUSTOMER LOYALTY

ENGAGING PRODUCT COPY

Our texts are aimed directly at your customers. They explain the benefits, added value and special features of the respective product quickly and simply.

TECHNICAL DRAWINGS – KNOW YOUR MEASUREMENTS

Judging the size of all kinds of tools from images can be difficult. That is why we created individual technical drawings for almost all of our products. We provide these to you so that your customers always know all the important measurements.

MACHINE ICONS FOR TOOL USE

Our clear machine icons show customers the machines on which they can use the respective tool.

CREATING CLARITY WITH THE LUKAS EVALUATION SYSTEM

We have organised our products into a single evaluation system with four clear criteria: work speed, service life, surface quality and handling/ergonomics. These criteria clearly illustrate the features of the respective LUKAS tool, allowing customers to judge for themselves which product is best for their goals and expectations. We provide our evaluation system as a .jpg file together with further informative product images, and you can easily integrate these in your shop.

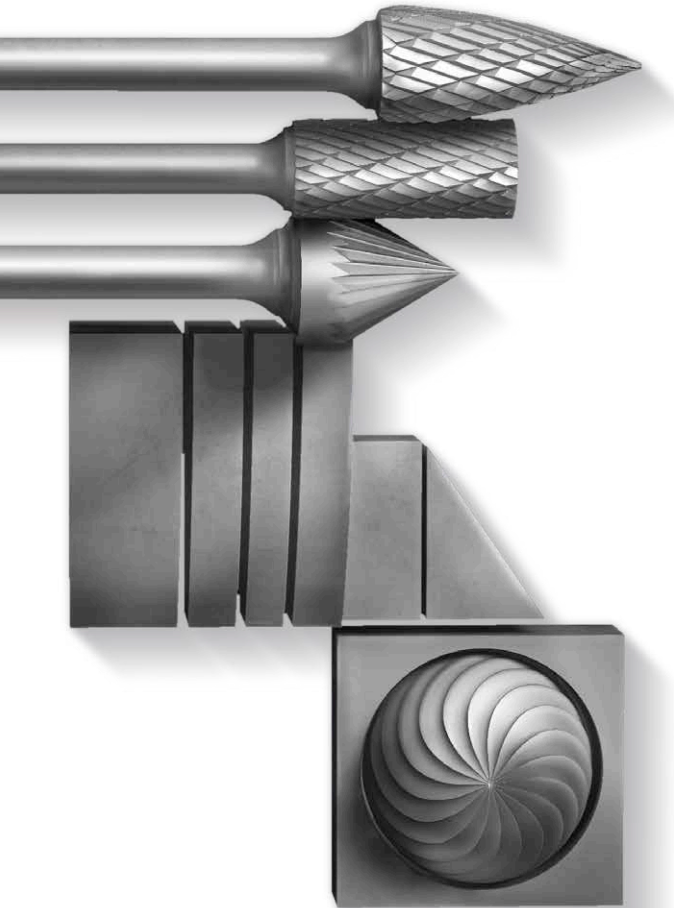

WHAT THE LUKAS DATA PACKAGE CAN OFFER YOU

DESIGNED FOR ONLINE CUSTOMERS

Our data is specially designed and optimised for online shops. We collaborated with the leading online retailers and an innovative PIM provider to analyse and prepare the most important product data. This means we can offer the exact data that your target customers look for.

THE FULL RANGE OF LUKAS PRODUCTS

Our current LUKAS Standard BMEcat contains a total of 3,500 items with excellent data quality. You are therefore certain to find something for your shop. We also keep these products in stock so that you can get even larger quantities delivered quickly.

LUKAS-SALES



“Gain easy access to critical edge over the competition: For retailers, support in data provision such as one that LUKAS provides can be crucial for business success. Our modern and up-to-date data quality combined with

reliable support is already convincing our dealers and customers.”

Timo Winter,
Sales Director at LUKAS

HIGH-QUALITY INFORMATION DELIVERS GREATER SALES

The data from LUKAS makes your online store more user-friendly by giving customers the precise information they need. By combining engaging text with clear images and icons, it shows the most important information at a glance. This means that instead of looking for more information sources, your customer stays on your shop site and purchases the products they need there.

LUKAS DATA CAN MAKE YOU FASTER AND MORE EFFICIENT

LUKAS offers uniquely comprehensive and informative product data that helps you generate more sales from your existing product range and grow into new markets quickly and easily. You can also benefit from cross-selling of accessories and associated products, thereby achieving greater margins.

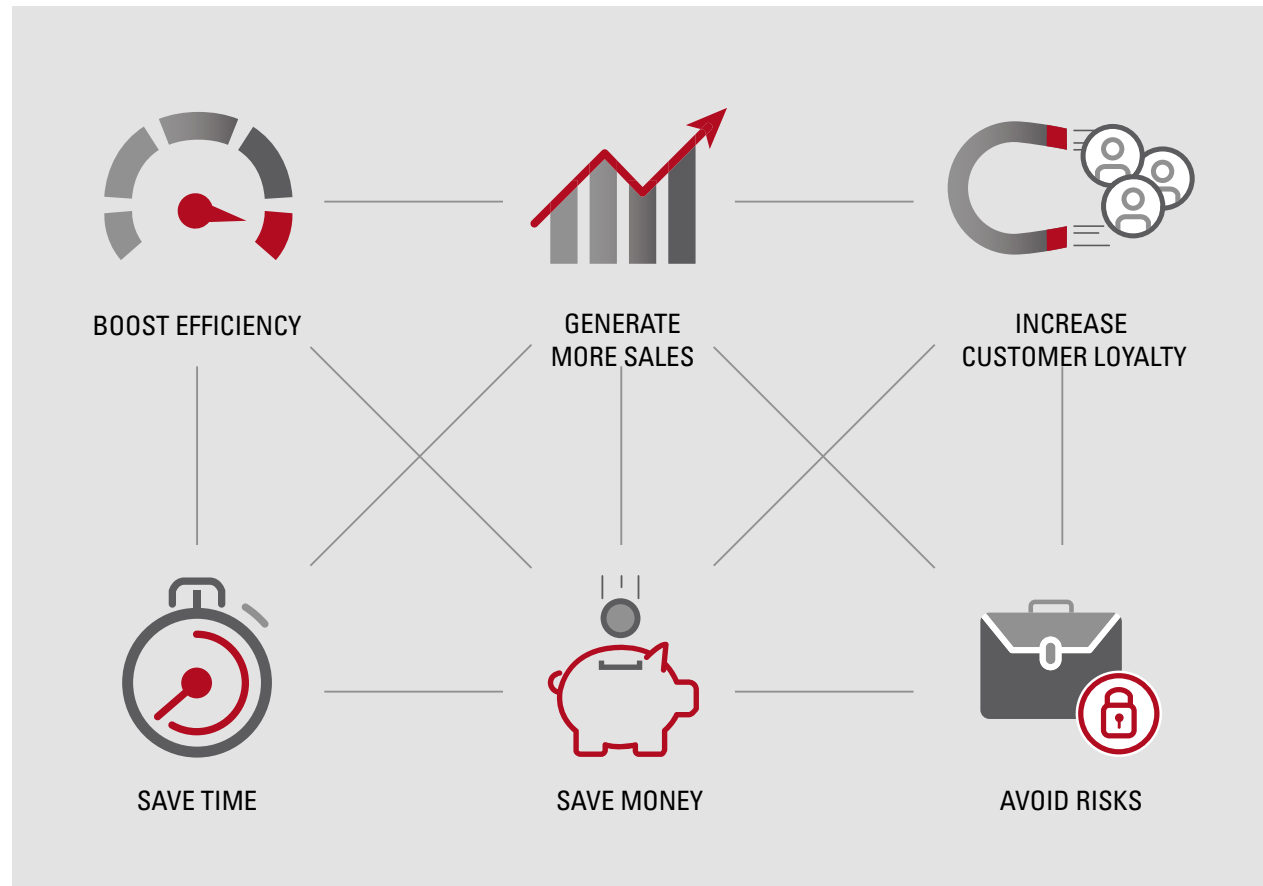

STANDARDISED FORMATS FOR QUICK SET-UP

The use of conventional formats (BMECat 2005, BMECat 1.2, CSV and XLSX) allows you to quickly incorporate the LUKAS Standard 360° data package into your ERP, PIM or online shop.

HIGH DATA QUALITY HELPS YOU SAVE TIME

Thanks to the high quality of the LUKAS data, you no longer have to waste time on painstaking data cleansing and tasks such as creating product photos, technical drawings and texts.

Comparing LUKAS data quality with the competition

MASTER DATA

All of the product data that customers need when placing an order, including the product number, a brief description, a customs tariff number or the product's country of origin. Both LUKAS and the competition achieve similarly good values here.

MEDIA

All product images (e.g. images of the product from different angles, images of the product in use, technical drawings or machine suitability). Just under a third of the possibilities are utilised by the competition. LUKAS provides you with all media.

FEATURES

This category covers the various technical features, including the tool's shape and dimensions. Compared to the competition, LUKAS provides additional value in the features that are important for e-commerce, such as copy explaining added value and benefits, marketing claims and a clear evaluation system.

ADDITIONAL INFORMATION

Additional information for a product includes data sheets, safety instructions, references and cross-selling information, for example. LUKAS provides virtually all possible additional information. By contrast, competitors place less value on this.

NUMERICAL VALUE

Utilised possibilities of the individual categories in percentage (on average for a product).

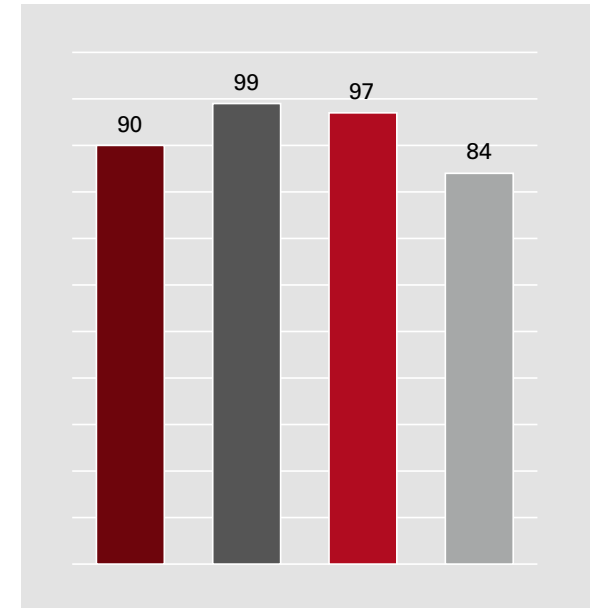

LUKAS data quality for the LUKAS Standard 360° data package

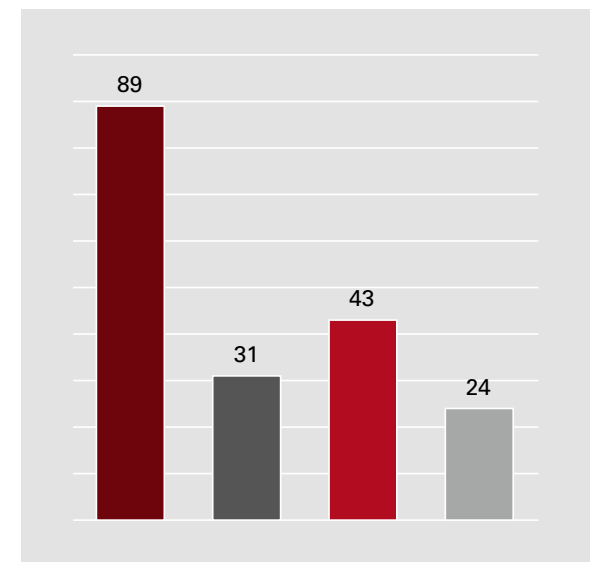

Competitor's current data quality (February 2020)

KNOWLEDGE TRANSFER FROM LUKAS

PRACTICAL TRAINING FROM LUKAS
FOR DEALERS AND CUSTOMERS



GRINDING • POLISHING • MILLING • CUTTING • CUSTOMISED TOOLS

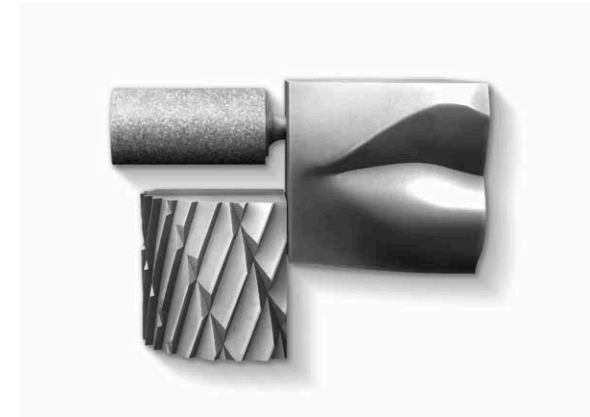

CREATE VALUE FOR CUSTOMERS

Do you want to stay up to date with the latest developments, find out about new technologies and tool applications, or simply find inspiration? We can help you and our shared customers with our tailored tool seminars and training sessions, held either at our own technology centre with practice area or at a location of your choice.

During these events, we present the latest innovations, introduce you to new technologies and show you how to get the best from LUKAS tools. Alongside this, our design and application engineers offer individual expert advice to help you find solutions to your challenges. You can also put our products through their paces and see how they are produced.

Our experts will be happy to share their knowledge and experience with you. Simply choose the right seminar or training event from our constantly expanding selection or get in touch with us. We would be happy to tailor our training to your needs.



LUKAS DEALER TRAINING

First-hand industry knowledge and the latest tool innovations

What do tool buyers expect today? How are the various products used? How can LUKAS' wide range of tools help users overcome challenges in different industries? What are the decisive factors and arguments that can influence purchasing decisions? Stay up to date and benefit from our expert knowledge in our dealer training events. You can also try out LUKAS tools yourself.

LUKAS USER TRAINING

Find out how to get the most from LUKAS tools

Learn through a combination of theory and practice how to use LUKAS tools for best results. Discover what they have to offer and find out how you can master any task. Our experts will be happy to answer your questions, discuss your challenges and find solutions together with you.



WE WELCOME
JUST UNDER

200

PARTICIPANTS TO OUR
SEMINARS ANNUALLY

LUKAS INDUSTRY DAYS

By professionals for professionals – discover our tools and overcome challenges

Put our tools to the test and find out about the wide range of applications. Our application engineers can show you why LUKAS tools have a reputation in industry as problem solvers, and how you can use them in an efficient and cost-effective way.

LUKAS ON SITE

We come to you with our fully equipped LUKAS mobile

Our LUKAS mobile contains everything you need for a professional tool seminar. In addition to quick staff training or application seminars at your location, it is also perfect for solving application problems, comparing performance characteristics or even improving your production processes. We would also be happy to support you at sales events or dealer trade fairs. We love a challenge.





LUKAS-ONLINE

ALWAYS STAY UP TO DATE: LUKAS ON FACEBOOK

Get the latest information about our trade fairs, new products and everything that is going on in our company. Our Facebook page provides the latest news, reports, videos and images from the world of tool production. Simply give us a like and you will never miss a thing.

<https://www.facebook.com/LukasErzett/>

EVERYTHING YOU NEED TO KNOW ABOUT LUKAS AND OUR TOOLS

Are you looking for information about our products, want to find out about our specialised industrial solutions, or just need the right contact partner in your sales area for questions? Our website has all the information you need. Click below to find everything you need to know about our products and services.

<https://www.lukas-erzett.com>

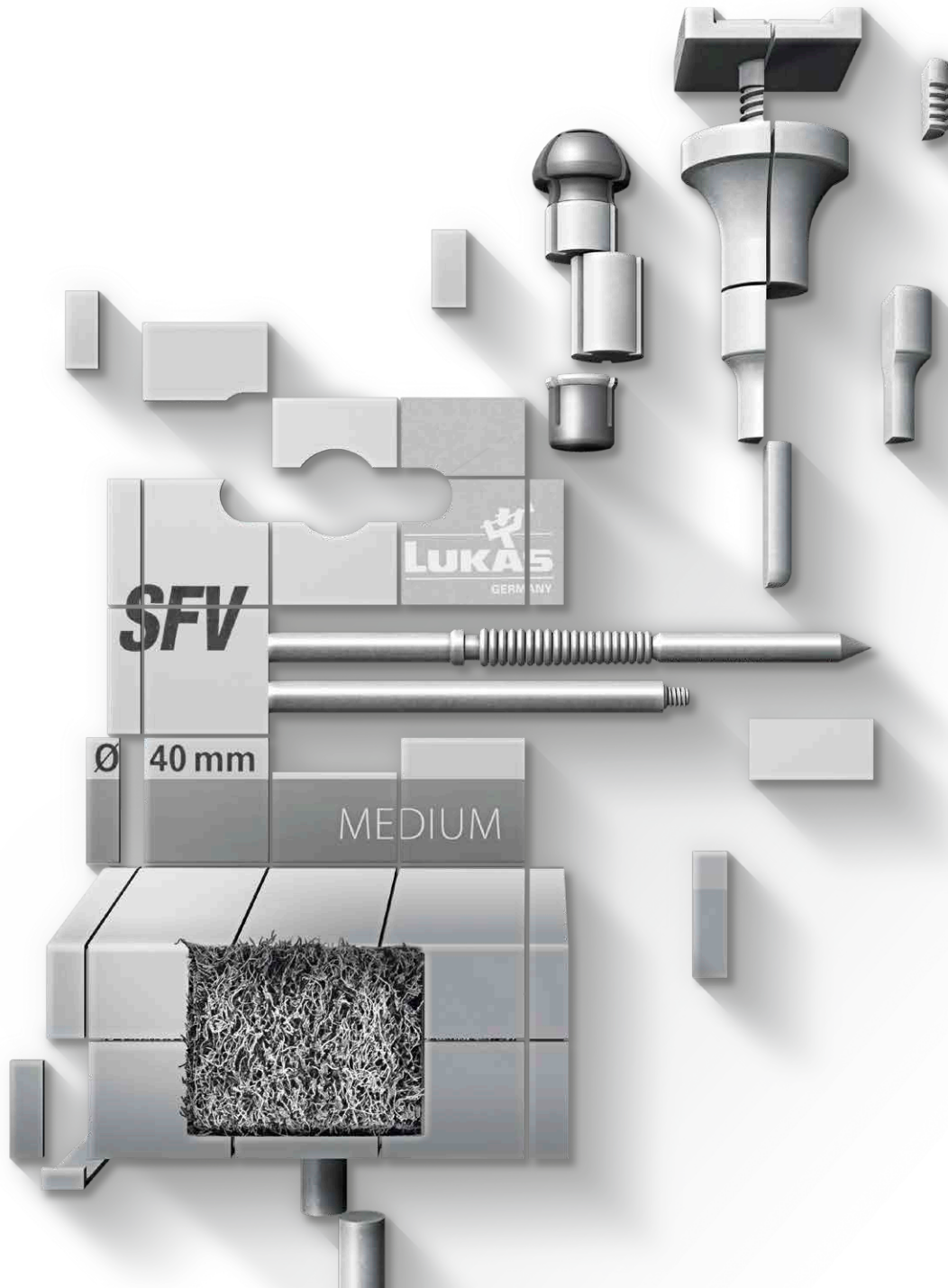

TAKE ADVANTAGE OF THE LUKAS SERVICE FOR RETAILERS

RETAIL TRADE SELECTION

As retailers, you know exactly what your customers want. Therefore you want to present and sell LUKAS products in a way that speaks to your customers.

We have just the right thing for you: the LUKAS presentation stand will help you boost your sales of industrial tools for cutting, milling, grinding and polishing for the long term.



THE LUKAS DISPLAY WALL

Stable, self-supporting presentation stand with perforated panel. Assemble your own, customised display panel with hook hangers for Euro hole packaging, hook hangers for all products with a hole, a brochure dispenser for further information or suspended shelves for boxes to display products in a professional way.

CARDBOARD COUNTER DISPLAY FOR CUTTING DISCS OR MOUNTED FLAP WHEELS

Presentation aid with quick assembly for presenting unique LUKAS mounted flap wheels or cutting and grinding discs on your sales counter. Available for tools with a diameter of 115 mm or 125 mm.

COUNTER DISPLAY FOR TUNGSTEN CARBIDE BURRS

Lockable display for presentation and individual sale of valuable LUKAS tungsten carbide burrs with a 3 mm or 6 mm shank. Place it on your sales counter or shelves.

OUR INDIVIDUAL PACKAGING

Eye-catching and informative individual packaging for the most popular LUKAS tools such as flap discs from the patented iQ series, tungsten carbide burrs, mounted flap wheels made of abrasive material, abrasive fleece or a combination of the two, as well as our mounted points selection for steel or inox. All of these are individually packaged and come with a Euro hole, available for your customised "display module" just like our cutting discs, diamond cutting discs, grinding discs and conventional flap discs, which you can simply hang on the display.

CARBIDE BURRS

The popular carbide burrs Z42 Inox/Steel and ZX Universal in practical retail packaging.

Pages 328/329

FLAP WHEELS

SFL, SFV and SFM flap wheels in retail packaging for a wide variety of applications. Pages 331/332

DIAMOND CUTTING DISCS

The efficient diamond cutting disc for the construction site and the inexpensive option for cutting tiles in retail packaging. Page 333

COUNTER DISPLAY, LOCKABLE

For the presentation and individual sale of LUKAS burrs. Place it on your sales counter or shelves.

Page 328



OUR RETAIL TRADE SELECTION



ADDITIONAL LUKAS PRODUCTS

This display wall is not only ideal for attractively presenting practical LUKAS retail trade products, many other LUKAS tools can also be displayed to advantage on the flexibly designed perforated stand. Select suitable products from the overview below and design your sales area the way you want.

DISPLAY WALL

Appeal to customers directly with LUKAS products.
Page 326

CUTTING DISC SETS

Various cutting disc sets in high quality, practical and secure metal boxes.
Page 327

MOUNTED POINTS SELECTION

Mounted points in various shapes in retail packaging. Ideal for letting your customers test our product.
Page 330

COUNTER DISPLAY

Counter display for up to 10 metal boxes of LUKAS cutting disc sets for direct dispensing to customers.
Page 326

DISPLAY ACCESSORIES

Presenting LUKAS tools made easy and attractive

LUKAS PRODUCT HIGHLIGHTS FOR YOUR DISPLAY STAND

Milling tools	Page 43
HZB special drill	Page 61
Diamond dry drills	Page 61
Diamond drill bit for socket outlets	Page 63
P6PT range	Page 117 – 119
Small polishing points with soft elastomer bond	Page 123
iQ series tools	Page 134 – 151
Additional mounted flap wheels	Page 152 – 161
Flap wheels	Page 164 – 180
LSL flap wheels in abrasive cloth with thread	Page 182
Fibre discs with backing plate	Page 236 – 241
Cutting discs	Page 244 – 259
Diamond cutting discs	Page 260 – 267
Grinding discs	Page 270 – 281
ASVT grinding disc	Page 287

All products can be found in the catalog "Product Range 2020/2021" on the pages specified here.

SPECIAL PACKAGED PRODUCTS FOR THE RETAILERS



★★★

The practical packaging for construction sites etc.

- cutting disc in metal box
- securely packaged
- protected from moisture

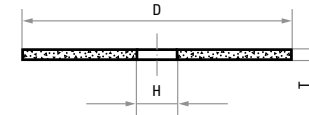

3-star cutting disc set



★★★

The practical packaging for construction sites etc.

- cutting disc in metal box
- securely packaged
- protected from moisture

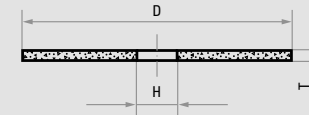

2-star cutting disc set



★★☆

The practical packaging for construction sites etc.

- cutting disc in metal box
- securely packaged
- protected from moisture

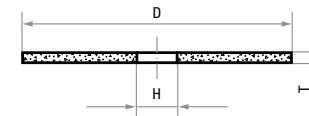

1-star cutting disc set



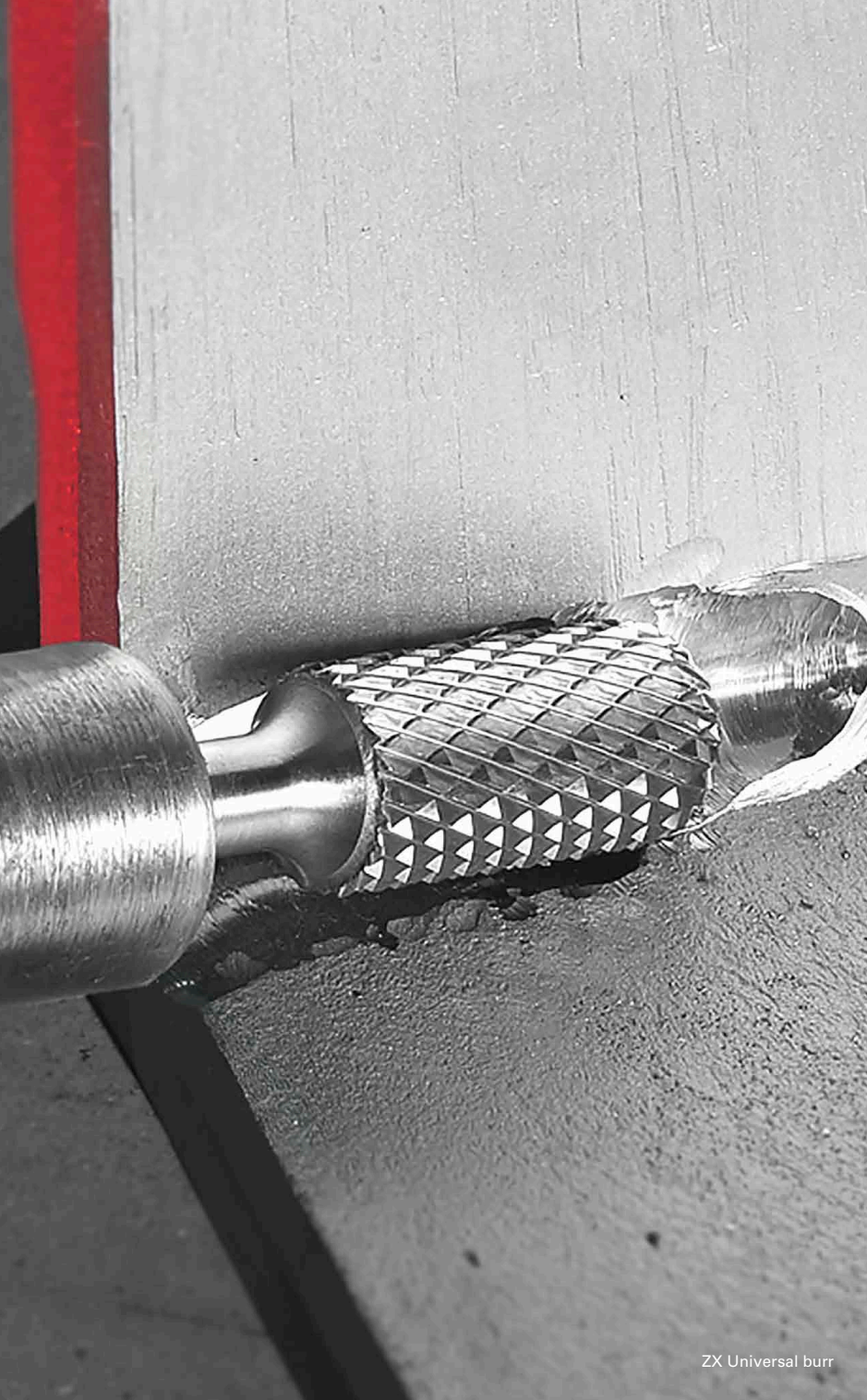

★☆☆

- for the presentation and individual sale of LUKAS carbide burrs with a 3 mm or 6 mm shank diameter
- lockable display
- also fits into shelves

Counter display for tungsten carbide burrs

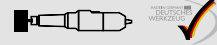

★★☆

- one burr for two materials: perfectly process steel and stainless steel with just a single tool
- in retail packaging
- high chip volume thanks to coarse cut for quick working
- faceted toothing for perfect surface results
- smooth running, low-vibration tool without chatter thanks to improved cutting angle

Z42 Inox/Steel burr

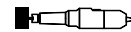
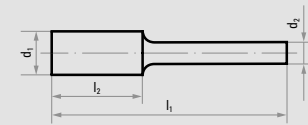

★☆☆

- the all-round burr for universal use in retail packaging
- with cross cut for high performance

ZX Universal burr

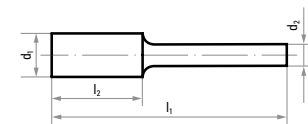

ZX Universal burr

Ceramic mounted point assortment

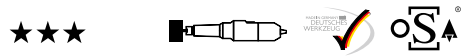

- maximum aggressiveness and hardness with ceramic self-sharpening effect
- five different shapes for fast tool change in retail packaging
- impressive tool life
- higher and faster stock removal particularly on hardened surfaces, scale, hard coatings and armour steel welds

Inox mounted point assortment

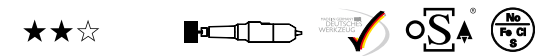

- for non-rusting steel
- 4 different shapes for fast tool changes, in specialist retail packaging
- excellent stock removal performance, also under adverse conditions



Steel mounted point assortment

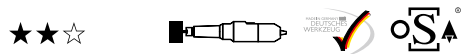

- top results with regular aluminium oxide, on structural steel, when rough grinding and finishing
- 5 different shapes for fast tool changes, in specialist retail packaging
- extremely hard and sharp for an impressively long tool life
- also machines hard materials efficiently

★★☆



SFL mounted flap wheels

- mounted flap wheels with abrasive cloth for manual use in retail packaging
- ideal for finishing, derusting, fettling, deburring, surface grinding, decorative finishing and bevelling
- impressive tool life working with various materials

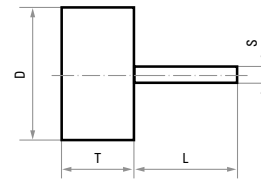

SFM mounted flap wheels

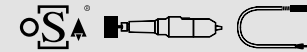

★★☆

- flap wheels with regular aluminium oxide in retail packaging
- in a combination of abrasive fleece and cloth for a high stock removal performance
- suitable for cleaning, derusting, pre-finishing, graining and keying

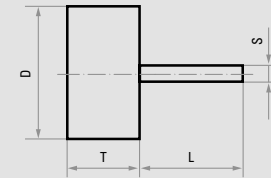

★★☆

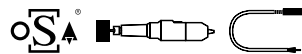

SFV mounted flap wheels

- flap wheels with regular aluminium oxide in retail packaging
- consisting of abrasive fleece flaps radially located around the hub of the tool
- ideal for matting, conditioning, polishing, finishing and fine surface finishing

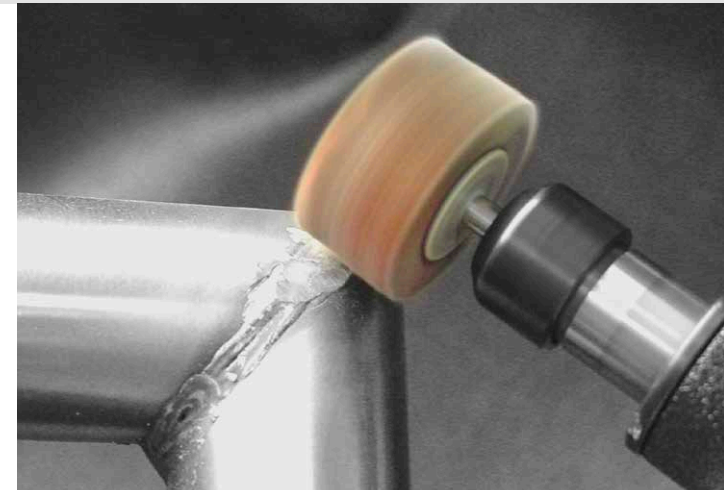
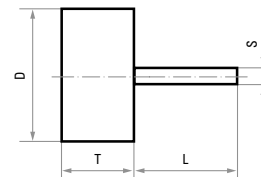

IDEAL FOR USE ON CONSTRUCTION SITES

LUKAS DIAMOND CUTTING
DISCS FOR EFFICIENT USE



This diamond cutting disc for construction sites is coated with synthetic diamonds bonded with an innovative alloy. It enables universal cutting of the hardest materials at a high operating speed.

Blue Cut S10 diamond cutting disc

FC7 diamond cutting disc





Blue Cut S10 diamond cutting disc

★☆☆



- in retail packaging
- especially popular on construction sites
- excellent price-to-performance ratio

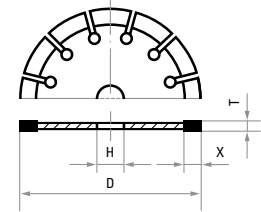

FC7 diamond cutting disc

★☆☆

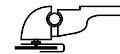

- in retail packaging
- especially popular on construction sites
- excellent price-to-performance ratio

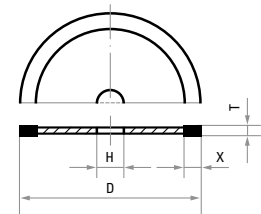

PRODUCTION AND SALES LOCATIONS



LUKAS-ERZETT GmbH & Co. KG

Gebrüder-Lukas-Straße 1
51766 Engelskirchen
Phone +49 2263 84-0
Fax +49 2263 84-327 (Domestic Sales)
Fax +49 2263 84-300 (International Sales)
le@lukas-erzett.de

Kayson Green Limited

Clough Road
Severalls Business Park Colchester
CO4 9QS Essex
Phone +44 1206 751500
Fax +44 1206 751212
abrasives@kaysongreen.co.uk

LUKAS CZ spol. s. r. o.

Tovární 478
35134 Skalná
Phone +420 357 070600
Fax +420 357 070613
obchod@lukascz.cz
www.lukas-erzett.com

LUKAS-ERZETT GmbH & Co. KG

C/Violeta, 1 Pol. Ind. El Lomo
28970 Humanes de Madrid
Phone 900 974 924
Fax 900 974 925
le@lukas-erzett.de

LUKAS ABRASIVES SA (PTY) LTD.

1288 Harriet Avenue
Driehoek
1401 Germiston
Phone +27 11 8251550
Fax +27 11 8720144
abrasives@lukas.co.za
www.lukas.co.za

Beijing Representative Office

Room 2228 · 19th Floor
C-King Apartment
No. 19 Madian East Rd.
100080 Haidian District Beijing
Phone +86 10 82961338
Fax +86 10 82800015
beijing@lukas-erzett.com.cn

LUKAS Tools Trading

Shanghai Co. Ltd.
In German Centre
Unit 313 B · Block 2, Tower 1
88 Keyuan Road
Zhang Jiang Hi-Tech Park
Pudong New District
201 203 Shanghai
lukas-trading@lukas-erzett.com